

# TE 22A - TA 32A



TA 32A

- Per il dettaglio, i piccoli supermercati e la ristorazione collettiva.
- Struttura in lega di alluminio lucidata ed anodizzata.
  - Bocca, coclea, volantino, bacinella (opzionale) e tramoggia in acc. inox AISI 304.
  - Tramoggia rimovibile.
  - Sistema di taglio Enterprise: 1 piastra e 1 coltello in acc. inox autoaffilanti, 1 estrattore.
  - Marcia, arresto ed inversione (reverse optional) con dispositivo N.V.R.

- For retail, small supermarkets and collective catering.
- Body of aluminium alloy polished and anodised.
  - Barrel, worm, locking ring and meat receiving tray (optional) made of stainless steel AISI 304.
  - Removable feed pan.
  - Enterprise version: 1 stainless steel holeplate and 1 self-sharpening knife, 1 extractor.
  - Marche, arret et inversion (optionnel) avec système NVR

- Pour le détail, les petits supermarchés et la restauration collective.
- Structure en alliage d'aluminium poli et anodisé.
  - Bouche, vis sans fin, écrou, plateau de reception viande (optionnel) en acier inoxydable AISI 304.
  - Trémie amovible.
  - Version Entreprise: 1 plaque et 1 couteau, 1 extracteur.
  - Vorwärtsgang, Stop und Rückwärtsgang (Rückwärtsgang wahlweise) mit NVR

- Für Lebensmitteleinzelhandel, kleine Supermärkte und Großgastronomie.
- Gehäuse aus Aluminiumlegierung, poliert und eloxiert.
  - Schnecke, Schneckengehäuse, Verschlussring, Empfangschale (optional) aus Edelstahl AISI 304.
  - Abnehmbarer Einfüllschüssel.
  - Enterprise Ausführung: 1 Lochscheibe und 1 Messer, 1 Ausziehvorrichtung.
  - Ein-Aus Drucktasten.
  - Vorwärtsgang, Stop und Rückwärtsgang (Rückwärtsgang wahlweise) mit NVR

- Para venta minorista, pequeños supermercados y restauración colectiva.
- Estructura de aleación de aluminio lustrada y anodizada.
  - Boca, còclea, volante y cubeta (opcional) de acero inoxidable.
  - Tolva extraíble.
  - Versión Enterprise: 1 placa inoxidable, 1 cuchilla autoafi lante y 1 extractor.
  - Marcha adelante, parada y marcha atrás (opcional) con dispositivo NVR

Tramoggia rimovibile - Removable feed pan -  
Abnehmbarer Einfüllschüssel - Trémie amovible - Tolva  
extraíble



TA 32A



TE 22V

## CARATTERISTICHE TECNICHE - TECHNICAL SPECIFICATIONS - TECHNISCHE DATEN - CARACTÉRISTIQUES - ESPECIFICACIONES

		TE 22A	TA 32A
Bocca - Head - Corps - Gehäuse - Boca		22/82	32/98
Produzione - Output - Production - Produktion - Producción	kg/h	270	500
Motore TF - Motor TPH, - Motor TPH - Moteur DPH - Motor TF	kW (HP)	0,75 (1)	2,20 (3,00)
Motore MF - Motor SPH - Motor EPH - Moteur MPH - Motor MF	kW (HP)	1,1 (1,5)	1,8 (2,5)
Peso netto TF (MF) - Net weight TPH (SPH) - Nettogewicht DPH (EPH) - Poids net TPH (MPH) - Peso neto TF (MF)	kg	32 (35) kg	60 (63) kg

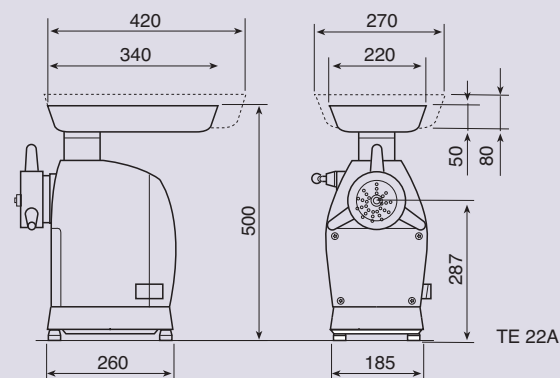

TE 22A

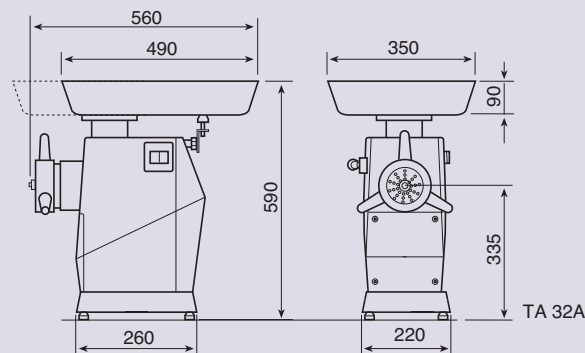

TA 32A

Macchina conforme alle  
norme in materia di igiene  
e di sicurezza, e alle norme  
specifiche per i tritacarne.

The machine complies with standards in terms of hygiene  
and safety and with the specific  
standards for meat mincers.



Enterprise