

300 GXE 350 GXL - 350 GXLA



350 GXL

AFFETTATRICI A GRAVITÀ

- Costruite in lega di alluminio trattata con ossidazione anodica.
- Affilatoio incorporato.
- Trasmissione ad ingranaggi.
- Per il dettaglio, i supermercati e la ristorazione collettiva.
- Comandi con dispositivo N.V.R.
- 350 GXLA - Versione automatica:
Movimento carrello automatico a una velocità, oppure manuale.
Motori indipendenti (lama e carrello).

GRAVITY SLICING MACHINES

- Made of aluminium alloy treated with anodic oxidation.
- Built-in sharpener.
- Gear drive.
- For supermarkets, hypermarkets, food retail and collective catering.
- Controls with N.V.R. device
- 350 GXLA - Automatic version:
Automatic one-speed carriage movement or else manual.
Independent motors (blade and carriage).

TRANCHEUSES À GRAVITÉ

- Réalisées en alliage d'aluminium traité par oxydation anodique.
- Aiguiser incorporé.
- Transmission à engrenages.
- Pour les supermarchés, les hypermarchés, le détail alimentaire et la restauration collective.
- Boutons Marche-Arrêt avec système NVR
- 350 GXLA - Version automatique:
Mouvement automatique chariot à une vitesse, ou bien manuel
Moteurs indépendants (lama et chariot).

SCHWERKRAFT-AUFSCHNITTMASCHINEN

- Ausgeführt aus Aluminiumlegierung, poliert und eloxiert.
- Eingebaute Schleifvorrichtung.
- Zahngetriebe.
- Für Lebensmitteleinzelhandel, Supermärkte, Hypermärkte und Großgastronomie.
- Ein-Aus Drucktaste mit NVR
- 350 GXLA - Automatik-Version:
Automatische Bewegung des Schlittens bei einer Geschwindigkeit oder manuell
Unabhängige Motoren (Klinge und Schlitten)

CORTADORAS DE FIAMBRES A GRAVEDAD

- Construidas en aleación de aluminio tratada con oxidación anódica.
- Afilador incorporado.
- Transmisión a engranajes.
- Para supermercados, hipermercados, venta minorista de alimentos y restauración colectiva.
- Mandos con dispositivo N.V.R.
- 350 GXLA - Versión automática:
Movimiento automático del carro a una velocidad o manual
Motores independientes (cuchilla y carro)



300 GXE

CARATTERISTICHE TECNICHE - TECHNICAL SPECIFICATIONS - TECHNISCHE DATEN - CARACTÉRISTIQUES - ESPECIFICACIONES

		300 GXE	350 GXL	350 GXLA automatica
diametro lama, diameter of the blade, diametre de la lame, Klingendurchmesser, diametro de la cuchilla	mm	300	350	350
motore, motor, moteur, Motor, motor	kW (HP)	0,30 (0,40)	0,37 (0,50)	0,37 (0,50)
motore carrello, carriage motor, moteur chariot, Schlittenmotor, motor carro	kW (HP)	-	-	0,18 (0,24)
corsa carrello, carriage stroke, course du chariot, Schilittenweglauf, carrera del carro	mm	320	340	340
ampiezza taglio, cut, ampleur de coupe, Schnittgröße, amplitud de corte	mm	190	250	250
ampiezza taglio, cut, ampleur de coupe, Schnittgröße, amplitud de corte	mm	170x290	200x280	200x280
spessore taglio, cut thickness, epaisseur de coupe, Schnittstärke, espesor de corte	mm	0/15	0/15	0/15
peso netto, net weight, poids net, Nettogewicht, peso neto	kg	30	41	66

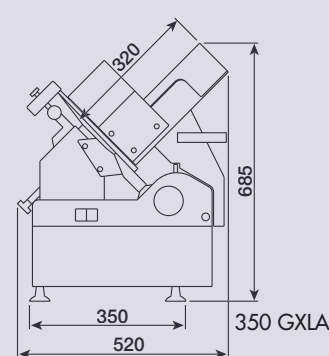
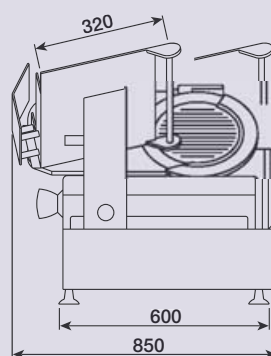
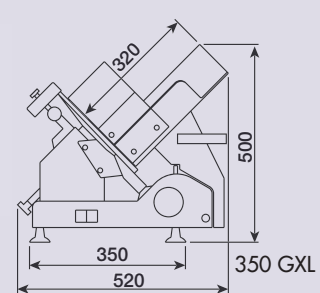
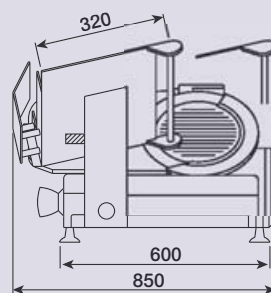
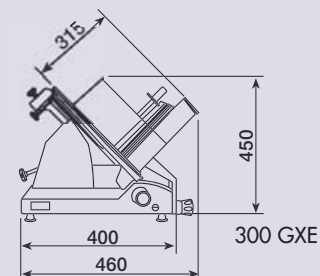
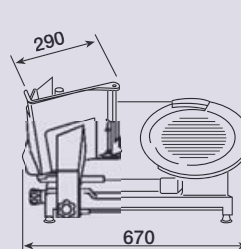

Macchina conforme alle norme CE in materia di igiene e di sicurezza.

The machine complies with CE standards in terms of hygiene and safety.